



# CREM<sup>®</sup>

## SC LINE



SC45



SC25

*Crafted for Every Taste*

# Main features – SC LINE

Flexible platform

1kg Bean hopper

18g Espresso brewer (SC45 ES and SC25 ES versions) or 14g Filter Brewer (SC25 BTB version)

Your story in 10" (SC45) or 7" (SC25) high-definition

Large waste capacity

3 instant canisters

Serviceability

One touch cleaning



## Main features – **SC LINE**

### Flexible platform

Here we are presenting the main version of SC LINE but the platform itself can do so much more. Should there be a need then we are able to configure the machine in a many different ways when it comes to brewer technology, bean hopper, instant canisters, water system and so forth.

### 18g Espresso brewer

SC45 ES and SC25 ES come with an 18g Espresso brewer. Thanks to accurate and adjustable dosing, brewing, and temperature controls, SC45 delivers outstanding coffee every time. We call this in cup quality.

### Your story in HD

Attract more customers with appealing artwork and comprehensive user menus to tell your specific story on SC45's 10" or SC25 7" touchscreen. Let everyone know what they are having in each cup.

### Large waste capacity

A small footprint does not always mean low capacity! The waste bin can handle the waste from 2 kg of beans, so approximately 200 cups of coffee. It is truly a champion in its class!

### 1kg Bean hopper

The 1kg bean hopper is made to really blend in with the design of the equipment. A 2kg bean hopper option is also available for locations with less frequent refill/empty service setup.

### 3 Instant canisters

SC LINE features three 2.2L ingredient canisters to increase the variety of drinks. The canisters can either be refilled when they are in the unit or by removing them. No matter how you do it, it's always quick and easy.

### Serviceability

SC LINE is designed to be serviced and maintained from the front. On-screen alerts to inform users and service personnel when cleaning, care and service are needed.

### One touch cleaning

SC LINE is cleaned with the touch of a button. Insert the tablets and just follow the on-screen instructions – SC LINEat it's finest.

*Style your*  
**SC LINE**

CREM



## Intuitive user interface

SC LINE has a user interface that is simple and easy to use. Users have the ability to customize their own drinks and choose from a variety of coffee favorites. For the true connoisseur, we offer the possibility to fine-tune their drinks.

You can easily manage and control the machine's hardware, stats, cleaning, maintenance, alerts and visual appearance. Match the interface's appearance with your decor or graphic profile. We can help you to control the color of the icons, wallpaper, screen saver, logo and image for brewing. All settings are designed to allow the machine to be adapted to the location and user.

On our machine, you get a high quality visual experience which can be varied over time. All to create a unique coffee experience.



## Style your screen

A personalised touch screen conveys a feeling of high quality. If you want to communicate your message to your customers, this is the right place to do it. There are several options available when personalising your screen.

### Logo

**CREM**<sup>®</sup>

Example logo

Use your own logo

Customized

### Background

Once you have started with the logo, make sure to change the background to match your graphical profile.

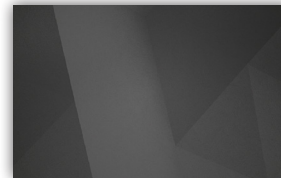

Default background

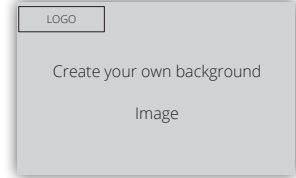

Customized

## Screensaver

When your coffee machine is not being used, it idles in screensaver mode in much the same way a computer would. Choose between using an image, slideshow or video.



Default video

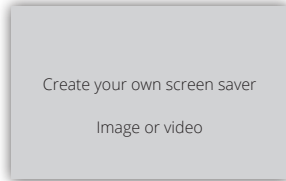

Customized

## Drink dispensing image or video

You can choose to show either an image or a video during preparation of the drink. This is the perfect opportunity to cross sell your product range, promote specials or reinforce your brand marketing.

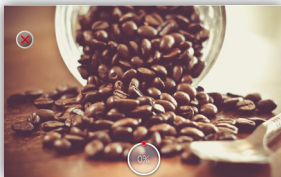

Default video

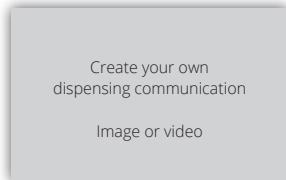

Customized





## Optimize your menu

SC LINE coffee menu comes with a wide range of taste-optimized recipes. However, SC45 can also enable customization of the menu to suit your needs. You can change and create new recipes as well as rename and place the icons in any order.

SC LINE is also provided with a function for displaying allergy information. The icons below are some of the icons that will be displayed on different beverages, after you enable the feature in the machine settings.



## Icons

In addition to changing your menu, you can change your icons as well. If you are interested in changing icons, we recommend that you contact us for more information on how to proceed.





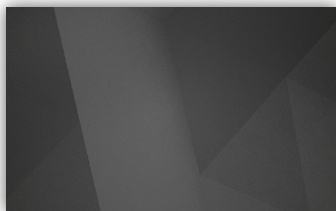

Background

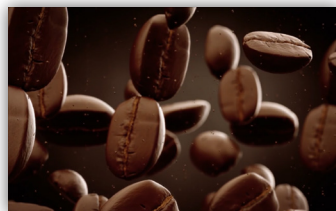

Screen Saver

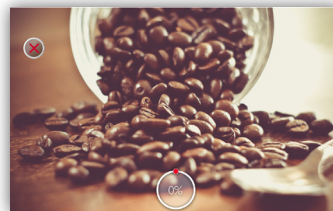

Preparation

# CREM®

Logo

## Screen specifications\*

	Width 10" / 7"	Height 10" / 7"	Format
<b>Logo</b>	199 px	56 px	.png
<b>Background</b>	1280 / 800 px	800 / 480 px	.png
<b>Screen saver</b>	1280 / 800 px	800 / 480 px	.png, .mp4
<b>Preparation image</b>	1280 / 800 px	800 / 480 px	.png

\* The pictures should not exceed 72 dpi. The file name can't contain, space \* / | \ , . : ; + = " < > [ ] and only consist of letters from the English alphabet.

## Our **espresso** technology

Espresso is an art. But unlike a fine painting, it can't be a one-time masterpiece, it has to be perfect and it has to be repeatable.

Our patented espresso brewer takes the stress out of espresso by making the perfect single or double shot every time - automatically.

Because every bean and roasting process has its own unique story to tell, our espresso brewer is adjustable for strength, dose size\*, extraction rate, and volume. So you can have your shot exactly the way you like it.

The perfect espresso must be bold, bright, and full-bodied with a rich crema carrying creamy notes of the beans' oil and earthiness. And since great espresso starts with good water, we always recommend using a high-quality water filtration system to ensure your espresso is never let down by off-tasting or poor quality water.

The espresso system utilizes the same methodology as a traditional espresso machine, and combines it with proprietary technology to provide a barista-quality espresso every time with just the push of a button.

\* Up to 18 gram.

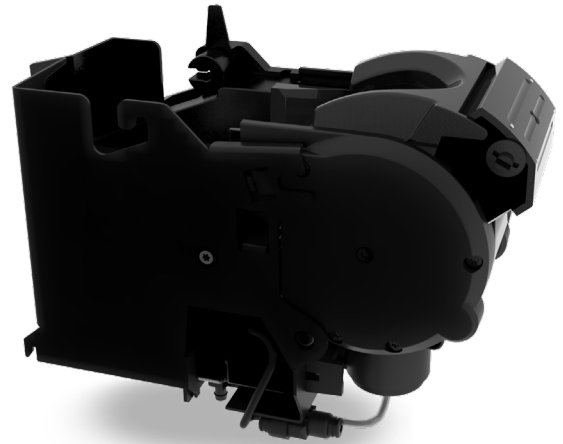

# Taste through technology

Our technology makes it possible for you to discover the unique flavors of each coffee bean. With SC45 you have the ability to control and change the entire process from bean to cup. Let the creativity flow - your unique coffee cup awaits you.

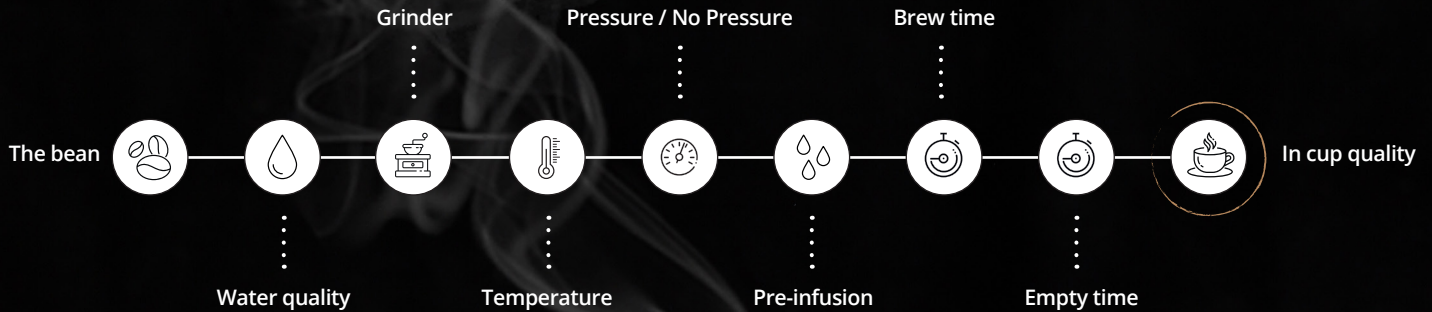



**It's our passion,** deep understanding and commitment to the coffee, and to you, that makes a **great coffee experience** possible.



## SC45 ES

- 10" Screen
- 1kg Bean hopper
- 1 Grinder
- 18g Espresso Brewer
- 3 Instant Canisters
- Adjustable Outlet
- Cup Sensors
- Separate Hot Water Outlet



## SC25 ES

---

- 7" Screen
- 1kg Bean hopper
- 1 Grinder
- 18g Espresso Brewer
- 3 Instant Canisters
- Adjustable Outlet
- Cup Sensors
- Separate Hot Water Outlet



## SC25 BTB

---

- 7" Screen
- 1kg Bean hopper
- 1 Grinder
- 14g Filter Brewer
- 3 Instant Canisters
- Adjustable Outlet
- Cup Sensors
- Separate Hot Water Outlet





# Cleaning and service information



Maintenance Report

Cleaning

Refill and Capacity Status

Error Report

Task

Reference

On screen instructions

Task	Reference	On screen instructions
Daily care	User manual / Cleaning & care manual	Yes
Weekly cleaning		
Monthly cleaning	Cleaning & care manual	Yes
6 month service	Technical manual	No
12 month service		

# Accessories



Brewer cleaning tablets

Art. 10037458



Grinder Cleaning tablets

Art. E1001001



Milk Cleaning / cleaning tablets

Art. 2060024



Water filter bestmax V

Art. 1505369



Water block

Art. 1206151



Serving jug

Art. 1103253



Cup dispenser

Art. 2760239



Condiment shelf

Art. 2760252

## What comes in the box

Accessories can vary depending on your specific configuration. We aim to include all general parts needed for a quick and easy installation of your machine.

- Instructions (quick start guidance & safety regulation)
- 1.8m pipe
- 1 pcs 3/4" adapter
- 2 pcs Locking clips
- 1 pcs Elbow connector
- 1 package brewer cleaning tablets (150 pcs)
- Mixer drip tray plate

## Dimensions SC45 & SC25

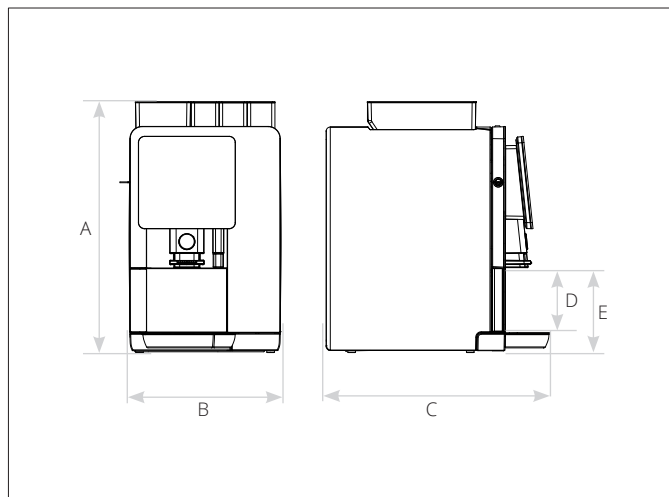

A	630mm
B	375mm
C	560mm
D	163mm
E	212mm

## Dimensions SC45 & SC25 with milk unit

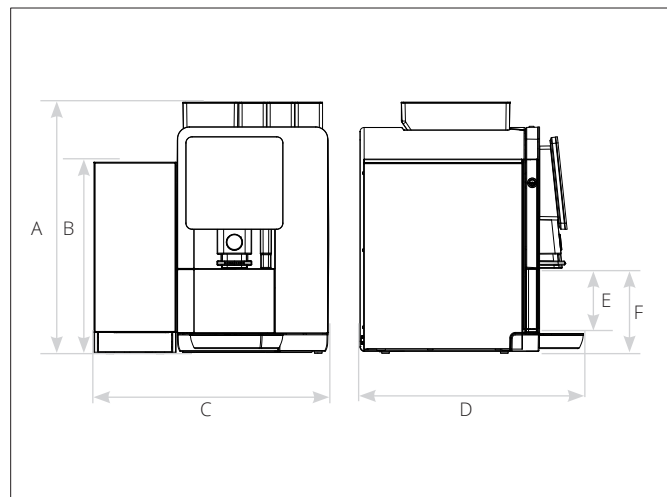

A	630mm
B	480mm
C	≥581mm
D	560mm
E	163mm
F	212mm

## Specifications

	SC45 ES	SC45 ES MILK	SC25 ES	SC25 ES MILK	SC25 BTB
<b>Bean hopper</b>	1	1	1	1	1
<b>Built-in grinder</b>	1	1	1	1	1
<b>Brewer</b>	Espresso 18g	Espresso 18g	Espresso 18g	Espresso 18g	Filter 14g
<b>CremTech SmartFoam</b>	No	Yes	No	Yes	No
<b>Screen</b>	10"	10"	8"	8"	8"
<b>Drink menu</b>	15 drinks / slide	15 drinks / slide	15 drinks / slide	15 drinks / slide	15 drinks / slide
<b>Recipe bank</b>	Up to 50 beverages	Up to 50 beverages	Up to 50 beverages	Up to 50 beverages	Up to 50 beverages
<b>Adjustable taste settings</b>	Yes	Yes	Yes	Yes	Yes
<b>Adjustable cup height</b>	Yes	Yes	Yes	Yes	Yes
<b>Intelligent energy save mode</b>	Yes	Yes	Yes	Yes	Yes
<b>Jug function</b>	Yes	Yes	Yes	Yes	Yes
<b>Cup sensor</b>	Yes	Yes	Yes	Yes	Yes
<b>Electronic temperature control</b>	Yes	Yes	Yes	Yes	Yes
<b>Cup counter</b>	Yes	Yes	Yes	Yes	Yes
<b>Waste bin present</b>	Yes	Yes	Yes	Yes	Yes
<b>Waste bin full (counter)</b>	Yes	Yes	Yes	Yes	Yes
<b>Separate hot water outlet</b>	Yes	Yes	Yes	Yes	Yes
<b>Built-in water filter</b>	No	No	No	No	No
<b>Power supply</b>	220-230VAC, 50/60Hz,	220-230VAC, 50/60Hz,	220-230VAC, 50/60Hz,	220-230VAC, 50/60Hz,	220-230VAC, 50/60Hz,
<b>Cold water connection</b>	3/4"	3/4"	3/4"	3/4"	3/4"
<b>Water tank volume</b>	700ml	700ml	700ml	700ml	700ml
<b>Inlet water temperature</b>	5 - 32°C	5 - 32°C	5 - 32°C	5 - 32°C	5 - 32°C
<b>Inlet water pressure range</b>	0.2-0.5 MPa (2-5 bar)	0.2-0.5 MPa (2-5 bar)	0.2-0.5 MPa (2-5 bar)	0.2-0.5 MPa (2-5 bar)	0.2-0.5 MPa (2-5 bar)
<b>Water hardness req. calcium</b>	20 - 32 ppm of calcium	20 - 32 ppm of calcium	20 - 32 ppm of calcium	20 - 32 ppm of calcium	20 - 32 ppm of calcium
<b>Ambient noise rating</b>	<70dB	<70dB	<70dB	<70dB	<70dB

## Bean hopper & waste capacity

	SC45	SC45 & SC25 with milk unit
Bean hopper	1kg / 3L	1kg / 3L
Bean hopper large (option)	2kg / 6L	2kg / 6L
Instant Coffee	2.2L	2.2L
Fresh Milk	N/A	4L
Topping	2.2L	2.2L
Chocolate	2.2L	2.2L
Drip tray	1.1L	1.1L
Waste bin	7.5L / 2kg	7.5L / 2kg
Cleaning container	2.2L	2.2L

## Energy declaration

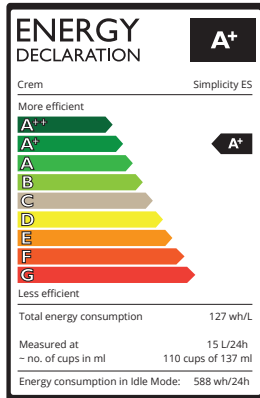

## Options & accessories

Cup dispenser	Optional
Condiment Shelf	Optional
Crem Tech SmartFoam	Optional

## Weight

Machine	36kg
Crem Tech SmartFoam	22.5kg
Machine + packaging	39.2kg
Crem Tech SmartFoam + packaging	24.5kg

## Packaging dimensions

	Height	Width	Depth
Machine carton	730mm	470mm	650mm
Milk unit carton	570mm	292mm	555mm

## Certifications



# CREM<sup>®</sup>

An Ali Group Company



*Crafted for Every Taste*

WWW.CREM.COFFEE